

CRUSHER FOR COMPLETE ANIMALS TYPE SMF





The crusher body is composed by heavy plates and profiles, completely welded and machined afterwards.

The fixed crushing teeth are welded on the side plates and kept by intermediate plates to obtain a very sturdy construction.

At the upper part, we have foreseen retaining teeth, to avoid that product and carcasses are turning around on the rotor teeth.

These teeth guarantee a continuous running of the crusher.

At the opposite wall, a row of fixed cleaning teeth are foreseen and also partially foreseen with hard facing material.

The central crusher shaft is made of high quality Cr-Ni steel.

The rotor assembly is made of crushing teeth and intermediate bushings, welded together and fixed on the central shaft, thus guaranteeing a complete sturdy assembled unit.

The position of our rotor teeth is such that forces on shaft and bearings are uniformly spread.

The strength of the shaft is calculated for the maximum power of the electric motor.

The rotor is directly connected to the "ROSSI MOTORIDUTTORI" gearbox with parallel axes and with motor driven with V-belt pulleys.



Bearing housing are made in two parts for easy maintenance and exchange of rotors. Both bearings and housings are calculated for heavy-duty circumstances, guaranteeing a long life. Completed with stuffing box flanges.



DETAIL OF THE SHAFT



CRUSHER WORKING

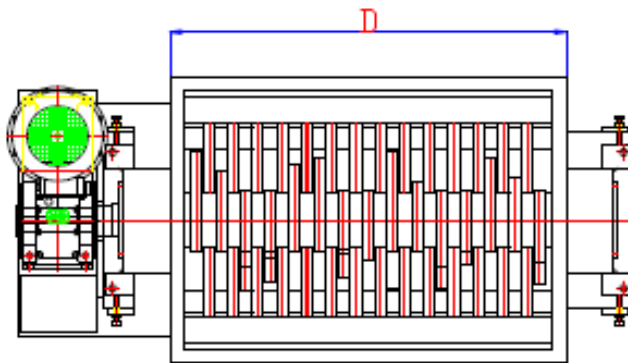
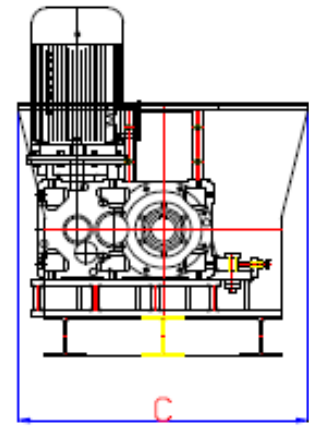
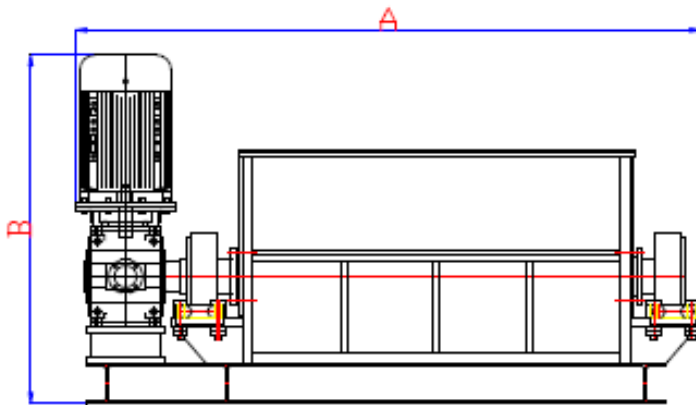

CRUSHER TYPE	DIMENSIONS mm.				N° OF TOOTH	PRODUCTION AT INLET TON/H	POWER KW	WEIGHT KG
	A	B	C	D				
SMF 400	2.810	1.592	1.300	1.780	15	25 - 30	45	6.500